



2,500 LBS WINCHES

NEW ITEMS IN BLUE | UPDATED APPLICATIONS IN RED

BRONCO[®]
ATV & UTV COMPONENTS

GENERATION I WINCH

GENERATION II WINCH

AC-12015 SERIES



AC-12018 SERIES



ALL WINCHES INCLUDE A UNIVERSAL MOUNTING BRACKET, HARDWARE, HANDLEBAR SWITCH, AND ELECTRICAL CONNECTIONS AS FEATURED BELOW



AC-12015
AC-12015-1
WIRED TYPE



AC-12018
AC-12018-1
WIRELESS TYPE

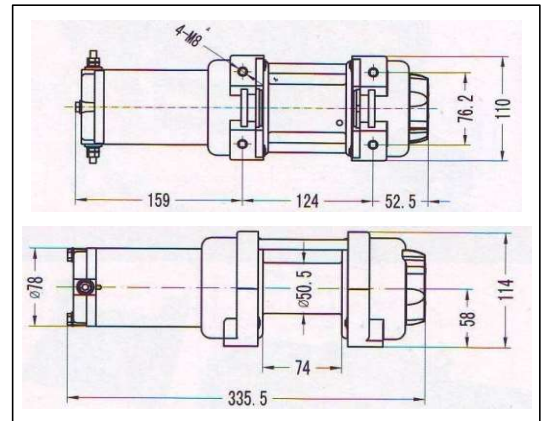

SPECIFICATIONS

RATED LINE PULL	2,500 LBS. (1,134KGS.) SINGLE-LINE
MOTOR	FULLY SEALED 12V DC, 0.9HP (700W) PERMANENT MAGNET
CONTROLS	HANDLEBAR MOUNTED MINI-ROCKER SWITCH
GEARING	3-STAGE PLANETARY
CLUTCH	FREESPOOLING; CAM ACTIVATED
BRAKE	AUTOMATIC
DRUM DIAMETER/ LENGTH	20" /2,9"
ROPE (in X ft) (mm X m)	AC-12015 SERIES: STEEL WIRE, 3/16" X 50' (4.8MM X 15.2M) AC-12018 SERIES: SYNTHETIC ROPE, 3/16" X 33' (4.8MM X 10M)
FAIRLEAD	HEAVY DUTY 4-WAY ROLLER
GEAR RATIO	136 : 1
HOOK	HEAVY DUTY, CLEVIS PINNED LATCH

PERFORMANCE DATA

LAYER	RATED LINE PULL LBS (KGS)	TOTAL ROPE ON DRUM FT (M)	LINE PULL LBS (KGS)	LINE SPEED	MOTOR (DRAW)
1	2,500 (1,134)	8.85 (2.7)	0	27ft (8.3m)	15 AMPS
2	2,134 (968)	19.22 (5.86)	1,000 (454)	20ft (6.1m)	60 AMPS
3	1,861 (844)	31.11 (9.48)	1,500 (680)	14ft (4.3m)	100 AMPS
4	1,650 (748)	44.52 (13.58)	2,000 (907)	10ft (3m)	130 AMPS
5	1,483 (673)	50.00 (15.2)	2,500 (1134)	7ft (2.1m)	160 AMPS